

73530-9993 Lightning

Age Range: 6 years and up
 Weight Limit: 150 lbs
 Surfaces: Hard
 Speed: 7 mph
 Colors: Black and Silver
 Intro: 2001
 Suggested Retail: \$249.99
 Box Dimensions:
 Warranty One Year Vehicle
 6 Months Battery

Advanced Series 12 Volt

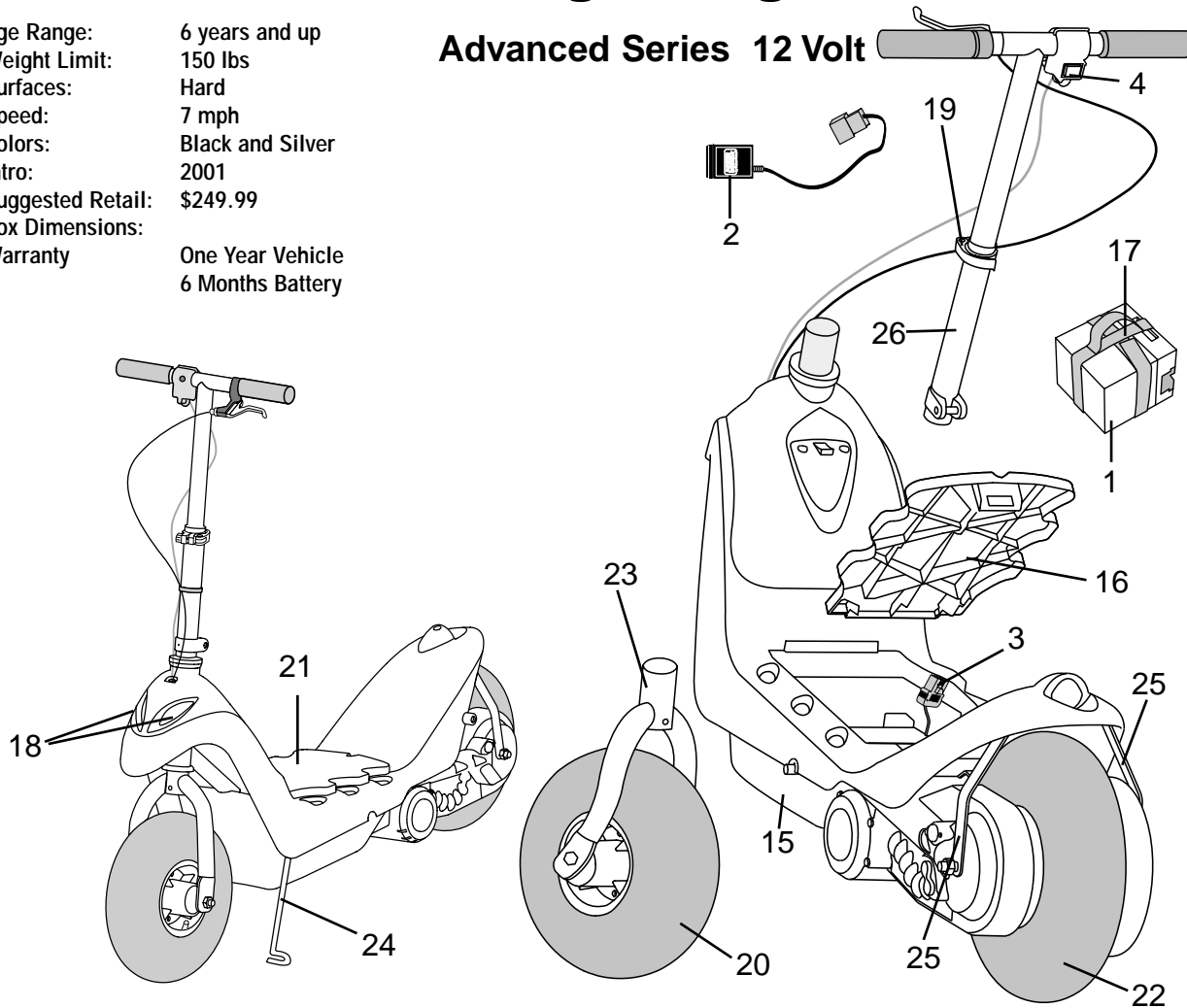

Item No.	Description	Part No.	Qty.	Item No.	Description	Part No.	Qty.	Item No.	Description	Part No.	Qty.
Working / Electrical Parts				Hardware / Metal Parts				Parts Not Shown			
1	Battery	00801-1048	1	23	Front Fork Assm	73530-9039	1		Owner's Manual	73530-0920	1
2	Charger, fused with probe	00801-0972	1	24	Kick Stand Assm.	73530-9279	1		Decal Sheet	73530-0310	1
3	Main Harness Assmly	00968-9002	1	25	Rear Bracket	73530-4009	2		Supl. Instruction Sheet	73530-0921	1
4	Handle Bar Electrical Assm.	73530-9549	1	26	Handle Bar Assm.	73530-9419	1		Lit Bag	73530-9059	1
Plastic / Other Parts											
15	Body/Scooter Base	N/A	1						Hardware Bag	73530-9459	1
16	Footboard	73530-9289	1						Drive Belt	73530-2289	1
17	Battery Strap	73530-5519	1						Tortion Spring for Kick Stand	73530-4589	1
18	Eye Reflector	73530-2379	2						PC Board	73530-9509	1
19	Front reflector w/bracket	73530-9249	1						Power Switch Harness	73530-9799	1
20	Front Wheel Assm.	73530-9249	1								
21	Foot Board Assm w/anti skid decal	73530-9289	1								
22	Rear Wheel Assm.	73530-9349	1								

N/A = Not Available

Items in **bold & underlined** print are only to be ordered by a service center.

Rev. 02-01-02 Pav

